



Copyright © 2004
T. Keith JAISTTT/AN1111

Operational Amplifiers

Magic Rules
Application Examples

UCSD: Physics 121; 2012

Op-Amp Introduction

- Op-amps (amplifiers/buffers in general) are drawn as a triangle in a circuit schematic
- There are two inputs
 - inverting and non-inverting
- And one output
- Also power connections (note no explicit ground)

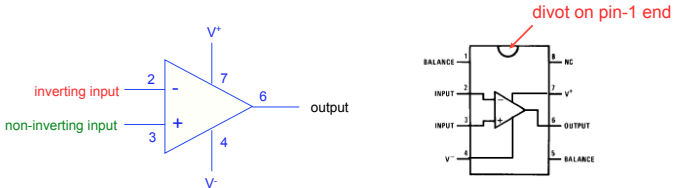

inverting input 2
non-inverting input 3
output 6
V+ 7
V- 4

BALANCE 1
INPUT 2
INPUT 3
V- 4
OUTPUT 6
V+ 7
NC 8

UCSD: Physics 121; 2012

Winter 2012 2

UCSD: Physics 121; 2012

The ideal op-amp

- Infinite voltage gain
 - a voltage difference at the two inputs is magnified infinitely
 - in truth, something like 200,000
 - means difference between + terminal and - terminal is amplified by 200,000!
- Infinite input impedance
 - no current flows into inputs
 - in truth, about $10^{12} \Omega$ for FET input op-amps
- Zero output impedance
 - rock-solid independent of load
 - roughly true up to current maximum (usually 5–25 mA)
- Infinitely fast (infinite bandwidth)
 - in truth, limited to few MHz range
 - slew rate limited to 0.5–20 V/ μ s

UCSD: Physics 121; 2012

Winter 2012 3

UCSD: Physics 121; 2012

Op-amp without feedback

- The internal op-amp formula is:

$$V_{out} = \text{gain} \times (V_+ - V_-)$$
- So if V_+ is greater than V_- , the output goes positive
- If V_- is greater than V_+ , the output goes negative

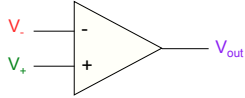

V-
V+
Vout

- A gain of 200,000 makes this device (as illustrated here) practically useless

UCSD: Physics 121; 2012

Winter 2012 4

UCSD: Physics 121; 2012

Infinite Gain in negative feedback

- Infinite gain would be useless except in the self-regulated negative feedback regime
 - negative feedback seems bad, and positive good—but in electronics positive feedback means runaway or oscillation, and negative feedback leads to stability
- Imagine hooking the output to the inverting terminal:
- If the output is less than V_{in} , it shoots positive
- If the output is greater than V_{in} , it shoots negative
 - result is that output quickly forces itself to be exactly V_{in}

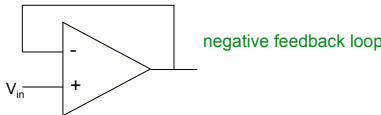

negative feedback loop

Winter 2012 5

UCSD: Physics 121; 2012

Even under load

- Even if we load the output (which as pictured wants to drag the output to ground)...
 - the op-amp will do everything it can within its current limitations to drive the output until the inverting input reaches V_{in}
 - negative feedback makes it self-correcting
 - in this case, the op-amp drives (or pulls, if V_{in} is negative) a current through the load until the output equals V_{in}
 - so what we have here is a buffer: can apply V_{in} to a load without burdening the source of V_{in} with any current!

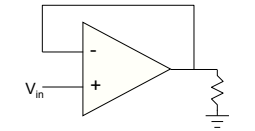

Important note: op-amp output terminal sources/sinks current at will: not like inputs that have no current flow

Winter 2012 6

UCSD: Physics 121; 2012

Positive feedback pathology

- In the configuration below, if the + input is even a smidge higher than V_{in} , the output goes way positive
- This makes the + terminal even more positive than V_{in} , making the situation worse
- This system will immediately “rail” at the supply voltage
 - could rail either direction, depending on initial offset

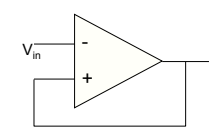

positive feedback: BAD

Winter 2012 7

UCSD: Physics 121; 2012

Op-Amp “Golden Rules”

- When an op-amp is configured in any negative-feedback arrangement, it will obey the following two rules:
 - The inputs to the op-amp draw or source no current (true whether negative feedback or not)
 - The op-amp output will do whatever it can (within its limitations) to make the voltage difference between the two inputs zero

Winter 2012 8

UCSD: Physics 121; 2012

Inverting amplifier example

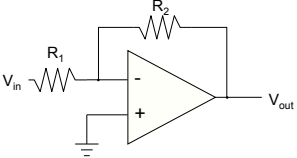

- Applying the rules: - terminal at “virtual ground”
 - so current through R_1 is $I_f = V_{in}/R_1$
- Current does not flow into op-amp (one of our rules)
 - so the current through R_1 must go through R_2
 - voltage drop across R_2 is then $I_f R_2 = V_{in} \times (R_2/R_1)$
- So $V_{out} = 0 - V_{in} \times (R_2/R_1) = -V_{in} \times (R_2/R_1)$
- Thus we amplify V_{in} by factor $-R_2/R_1$
 - negative sign earns title “inverting” amplifier
- Current is *drawn into* op-amp output terminal

Winter 20129

UCSD: Physics 121; 2012

Non-inverting Amplifier

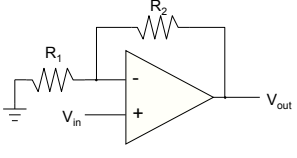

- Now neg. terminal held at V_{in}
 - so current through R_1 is $I_f = V_{in}/R_1$ (to left, into ground)
- This current cannot come from op-amp input
 - so comes through R_2 (delivered from op-amp output)
 - voltage drop across R_2 is $I_f R_2 = V_{in} \times (R_2/R_1)$
 - so that output is higher than neg. input terminal by $V_{in} \times (R_2/R_1)$
 - $V_{out} = V_{in} + V_{in} \times (R_2/R_1) = V_{in} \times (1 + R_2/R_1)$
 - thus gain is $(1 + R_2/R_1)$, and is positive
- Current is *sourced* from op-amp output in this example

Winter 201210

UCSD: Physics 121; 2012

Summing Amplifier

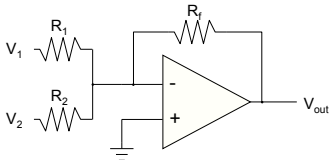

- Much like the inverting amplifier, but with two input voltages
 - inverting input still held at virtual ground
 - I_1 and I_2 are added together to run through R_f
 - so we get the (inverted) sum: $V_{out} = -R_f \times (V_1/R_1 + V_2/R_2)$
 - if $R_2 = R_1$, we get a sum proportional to $(V_1 + V_2)$
- Can have any number of summing inputs
 - we'll make our D/A converter this way

Winter 201211

UCSD: Physics 121; 2012

Differencing Amplifier

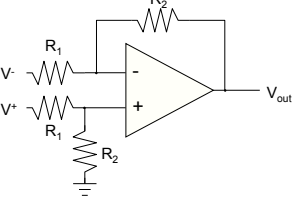

- The non-inverting input is a simple voltage divider:
 - $V_{node} = V^+ R_2 / (R_1 + R_2)$
- So $I_f = (V^- - V_{node}) / R_1$
 - $V_{out} = V_{node} - I_f R_2 = V^+ (1 + R_2/R_1) (R_2 / (R_1 + R_2)) - V^- (R_2/R_1)$
 - so $V_{out} = (R_2/R_1) (V^+ - V^-)$
 - therefore we difference V^+ and V^-

Winter 201212

UCSD: Physics 121; 2012

Differentiator (high-pass)

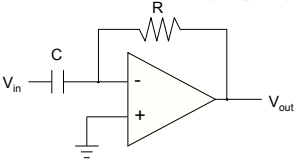

- For a capacitor, $Q = CV$, so $I_{cap} = dQ/dt = C \cdot dV/dt$
 - Thus $V_{out} = -I_{cap}R = -RC \cdot dV/dt$
- So we have a differentiator, or high-pass filter
 - if signal is $V_0 \sin \omega t$, $V_{out} = -V_0 RC \omega \cos \omega t$
 - the ω -dependence means higher frequencies amplified more

Winter 2012

13

UCSD: Physics 121; 2012

Low-pass filter (integrator)

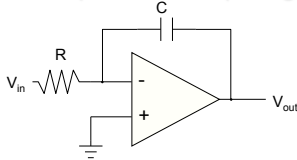

- $I_f = V_{in}/R$, so $C \cdot dV_{cap}/dt = V_{in}/R$
 - and since left side of capacitor is at virtual ground:

$$-dV_{out}/dt = V_{in}/RC$$
 - so $V_{out} = -\frac{1}{RC} \int V_{in} dt$
 - and therefore we have an integrator (low pass)

Winter 2012

14

UCSD: Physics 121; 2012

RTD Readout Scheme

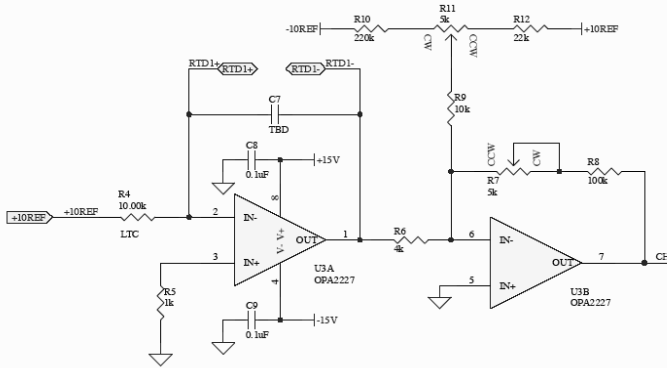

Winter 2012

15

UCSD: Physics 121; 2012

Notes on RTD readout

- RTD has resistance $R = 1000 + 3.85 \times T(^{\circ}\text{C})$
- Goal: put 1.00 mA across RTD and present output voltage proportional to temperature: $V_{out} = V_0 + \alpha T$
- First stage:
 - put precision 10.00 V reference across precision 10k Ω resistor to make 1.00 mA, sending across RTD
 - output is -1 V at 0 $^{\circ}\text{C}$; -1.385 V at 100 $^{\circ}\text{C}$
- Second stage:
 - resistor network produces 0.25 mA of source through R9
 - R6 slurps 0.25 mA when stage 1 output is -1 V
 - so no current through feedback \rightarrow output is zero volts
 - At 100 $^{\circ}\text{C}$, R6 slurps 0.346 mA, leaving net 0.096 that must come through feedback
 - If $R7 + R8 = 10389$ ohms, output is 1.0 V at 100 $^{\circ}\text{C}$
- Tuning resistors R11, R7 allows control over offset and gain, respectively: this config set up for $V_{out} = 0.01 T$

Winter 2012

16

UCSD: Physics 121; 2012

Hiding Distortion

- Consider the "push-pull" transistor arrangement to the right
 - an npn transistor (top) and a pnp (bot)
 - wimpy input can drive big load (speaker?)
 - base-emitter voltage differs by 0.6V in each transistor (emitter has arrow)
 - input has to be higher than -0.6 V for the npn to become active
 - input has to be lower than -0.6 V for the pnp to be active
- There is a no-man's land in between where neither transistor conducts, so one would get "crossover distortion"
 - output is zero while input signal is between -0.6 and 0.6 V

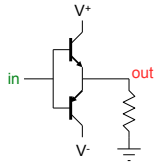
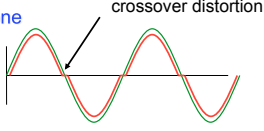



crossover distortion

Winter 2012 17

UCSD: Physics 121; 2012

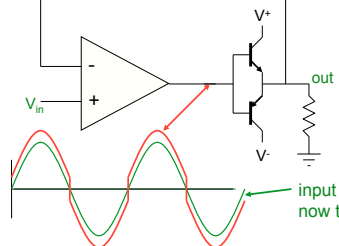
Stick it in the feedback loop!



input and output now the same

- By sticking the push-pull into an op-amp's feedback loop, we guarantee that the output **faithfully** follows the input!
 - after all, the golden rule demands that $+ \text{input} = - \text{input}$
- Op-amp jerks up to 0.6 and down to -0.6 at the crossover
 - it's **almost magic**: it figures out the vagaries/nonlinearities of the thing in the loop
- Now get advantages of push-pull drive capability, without the mess

Winter 2012 18

UCSD: Physics 121; 2012

Dogs in the Feedback

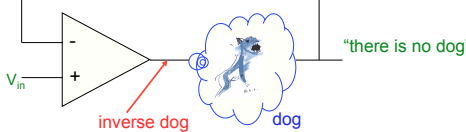

"there is no dog"

- The op-amp is obligated to contrive the **inverse dog** so that the ultimate output may be as tidy as the input.
- Lesson: you can hide nasty nonlinearities in the feedback loop and the op-amp will "do the right thing"

We owe thanks to Hayes & Horowitz, p. 173 of the student manual companion to the *Art of Electronics* for this priceless metaphor.

Winter 2012 19

UCSD: Physics 121; 2012

Reading

- Read 6.4.2, 6.4.3
- Pay special attention to Figure 6.66 (6.59 in 3rd ed.)

Winter 2012 20